

Xtralift 2.0

UK 21 Person Square (1600kg)

MRL Traction

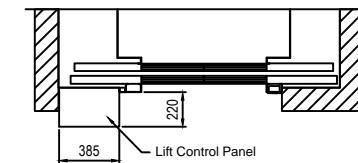
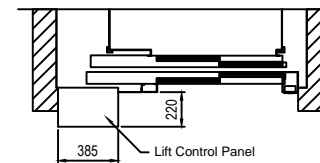
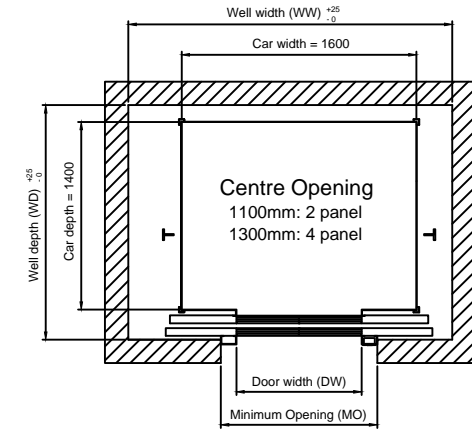
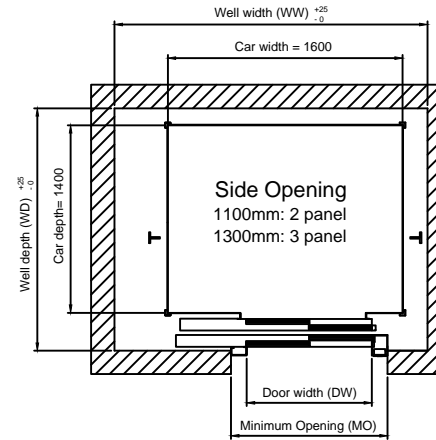
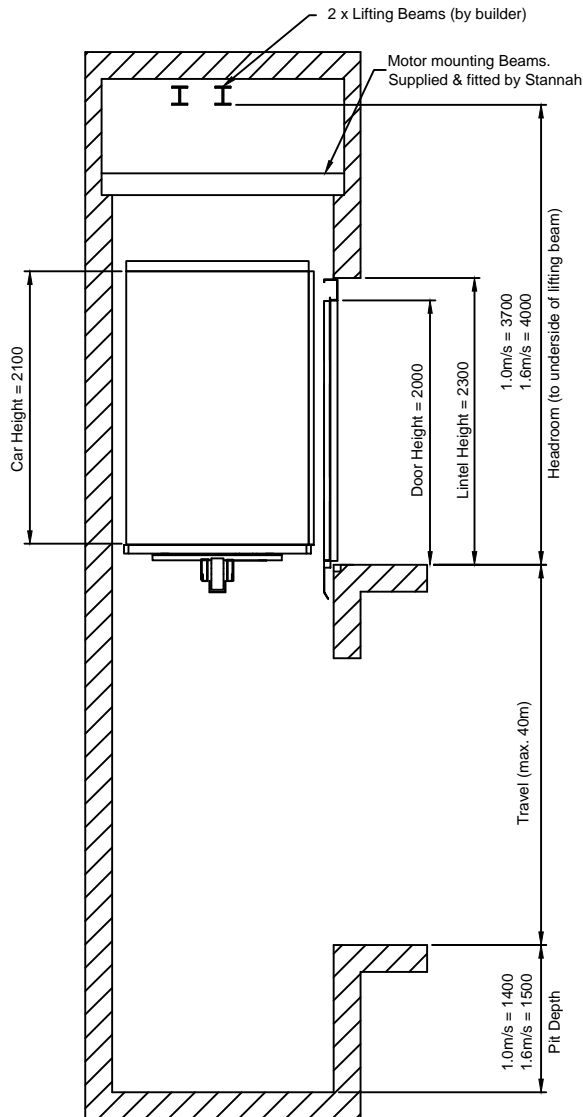

Lift Control Panel located at top floor or one level below. It can be mounted next to the landing entrance or remotely mounted within 5m of the lift shaft

		Shaft Size				
		Single Entrance		Through Entrance		
DW	Door type	WW	WD	WW	WD	MO
1100	Side Opening	3100	2100	3100	2100	1400
	Centre Opening	3100	2100	3100	2100	
1300	Side Opening	3100	2100	3100	2250	1600
	Centre Opening	3100	2100	3100	2150	

Waiver:

This data sheet is for guidance only and must not be used for proper working drawings. Please contact Stannah Lifts for particular details before proceeding. Owing to our policy of continual improvement we reserve the right to alter specifications and dimensions without prior notice

Stannah Lifts Ltd.
Anton Mill, Andover, Hampshire. SP10 2NX

Tel: 01264 339090

www.stannahlifts.co.uk

Information Sheet

X4-3

20/6/15